

FAN COIL

Water-supplied decentral
unit with EC-fan

Water-supplied decentral unit with EC-fan for heating and cooling. Air amounts from 170 to 910 m³/h.



For more information,
downloads and videos,
visit the Fan Coil page
on our website





High comfort with small dimensions in a modern design



The FAN COIL is a decentralized unit for low temperature heating systems and cooling. The unit is equipped with a low-noise EC fan and can easily be combined with a heat pump system.

The FAN COIL unit has a very low water content and can therefore react quickly. This ensures maximum controllability, which is the ideal basis for contemporary heating and cooling.

The FAN COIL is designed for use in smaller spaces such as offices, shops, living rooms and garages.

Product features

- 8 sizes and 2 versions
- Casing made of galvanized steel with a RAL 9010 coating
- Copper / aluminum heat exchanger
- Cleanable synthetic air filter type G2
- Reliable low-noise EC fan



Dimensions

T	A	B	C	Ø
030	840	400	480	1/2"
050	1040	600	680	1/2"
070	1240	800	880	1/2"
100	1640	1200	1280	3/4"

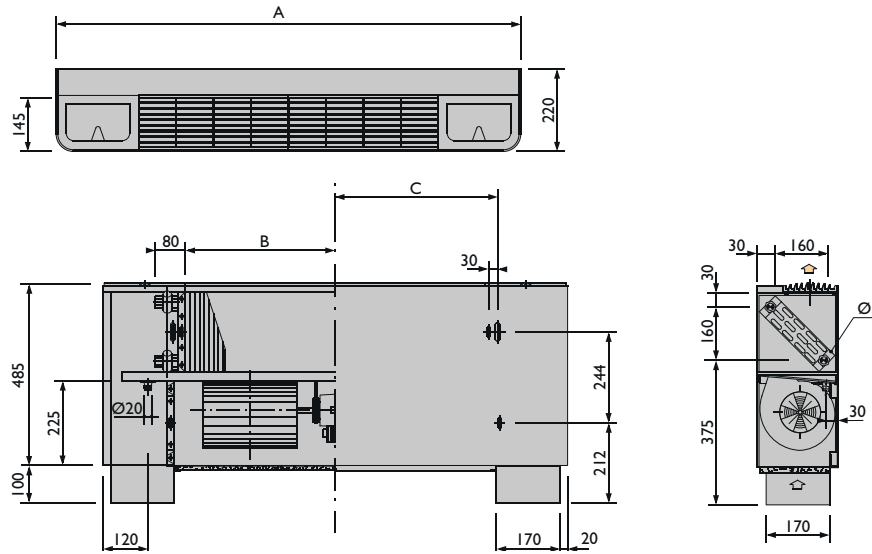

Technical information

Type		030	050	070	100	034	054	074	104
Total cooling capacity 7/12°C, T=27, rv=50	H - kW (10V)	2,18	3,11	4,57	5,36	2,18	3,11	4,57	5,36
	M - kW (6V)	1,44	2,35	3,53	4,05	1,44	2,35	3,53	4,05
	L - kW (2V)	0,98	1,24	1,59	1,77	0,98	1,24	1,59	1,77
Sensible cooling capacity 7/12°C, T=27, rv=50	H - kW (10V)	1,75	2,15	3,02	3,58	1,75	2,15	3,02	3,58
	M - kW (6V)	1,35	1,67	2,35	2,84	1,35	1,67	2,35	2,84
	L - kW (2V)	0,75	0,89	1,09	1,22	0,75	0,89	1,09	1,22
Water flow	l/h (10V)	374	533	783	920	374	533	783	920
Pressure drop	kPa	3,7	7,8	12,7	6,9	3,7	7,8	12,7	6,9
Heating capacity 60/40°C, T=20	H - kW (10V)	3,12	4,24	6,14	7,24	1,07	1,75	2,63	2,72
	M - kW (6V)	2,34	3,24	4,71	5,44	0,87	1,41	2,13	2,16
	L - kW (2V)	1,30	1,74	2,11	2,41	0,53	0,86	1,13	1,14
Water flow*	l/h (10V)	137	186	270	318	47	77	115	120
Heating capacity 50/43°C, T=20	H - kW (10V)	3,26	4,03	5,64	6,68	2,50	3,24	4,54	5,32
	M - kW (6V)	2,44	3,08	4,33	5,02	2,03	2,61	3,67	4,22
	L - kW (2V)	1,36	1,65	1,94	2,22	1,24	1,60	1,95	2,23
Water flow**	l/h (10V)	374	533	783	920	220	285	399	467
Pressure drop	kPa	3,2	7,0	11,2	6,3	7,3	13,5	21,2	8,8
Air amount	H - m³/h (10V)	495	540	745	910	495	540	745	910
	M - m³/h (6V)	360	390	540	620	360	390	540	620
	L - m³/h (2V)	170	190	215	245	170	190	215	245
Sound level	dB(A) (10V)	47	48	45	48	47	48	45	48
Supply voltage	V/Ph/Hz	210-230/1/50-60							
Power consumption	W (10V)	43	44	49	55	43	44	49	55
Current consumption	A (10V)	0,28	0,30	0,34	0,37	0,28	0,30	0,34	0,37
Water connections	Nr. x "	2 x 1/2" F							
Weight	kg	24	27	39	55	25,5	28,5	41	57

H = high speed, M = medium speed, L = low speed



Controls

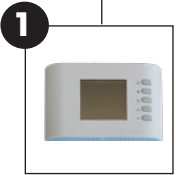

Control combination options

Fan Coil + **1**

1 = Room thermostat with speed control (5997350)